

2023-03-21 Atholl SCDC - John's programme marking RSCDS Centenary

1 EH3 7AF J32 · 3/4L

Roy Goldring: RSCDS XL 6 · Crib: MiniCribs · Diagram: Keith Rose's Diagrams

- 1-8 1s lead down the middle & back to top. 2s & 3s step in on bar 8 ready for ...
- 9-16 1s+2s+3s Promenade ending with 1s casting to 2nd place
- 17-24 1s pass by the right & turn 1st corners RH to end L between 2s & M between 3s, 1s pass by the right & turn 2nd corners RH to end between cnrns
- 25-32 1M dances RH across with 2s & 1L with 3s, 1L dances up between 2s & casts to 2nd place own side as 1M dances between 3s & casts up

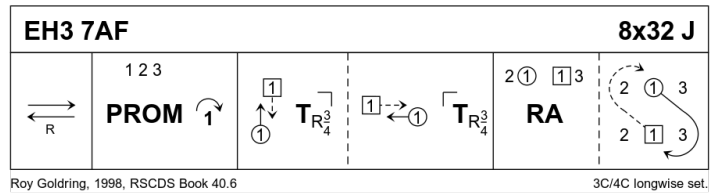

2 THE INIMITABLE DEREK R32 · 3/4L

Roy Goldring: Magazine Dances 2005-2009 · Crib: MiniCribs · Diagram: Keith Rose's Diagrams

- 1-8 1s+2s turn 1.1/4 times on sides (Ladies LH, Men RH) to end in line across 1s BtoB, 1s+2s set, Ladies 3/4 turn RH **while** Men turn 3/4 LH. 2 1 3
- 9-16 1s dance 1/2 reels of 3 on sides (1L in & up, 1M in & down), 2s+3s continue reel **while** 1s cross to join other reel (1L crosses down to 3rd place Men's side **while** 1M crosses up to 1st place Ladies side) & 1s turn 3M/2L RH to end in a diagonal line between 2nd corners
- 17-24 1s Bal-in-Line with 2nd corners, 1s turn LH & Bal-in-Line with 1st corners, 1s turn LH to...
- 25-32 1s dance RH across on sides (1L with 2L+3L, 1M with 2M+3M), 1L dances up & casts to 2nd pl own side **while** 1M dances down & casts up to 2nd pl

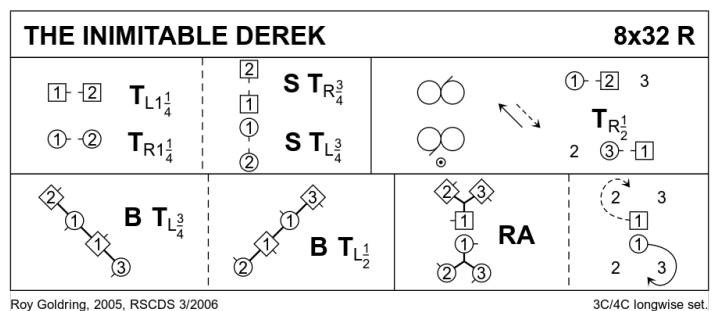

3 RUBY WILKINSON'S FAREWELL TO CRANSHAWS S32 · 4/4L

Alasdair Brown: RSCDS LII 6 · Crib: MiniCribs · Diagram: Keith Rose's Diagrams

2 chords - 2nd chord 3s+4s cross to opp sides

- 1-8 1s+4s set, cast down/up to 2nd/3rd places (2s+3s step up/down bars 3-4). 1s+4s turn 1/2 LH & dance 1/2 LH across to 1M facing 3L, 1L+3M, 4M+2L, 4L+2M
- 9-16 4s+1s dance diagonal interlocking reels of 4 with corner positions (LH across 1/2 way in middle) **while** 2s (in 1st place) & 3s (in 4th place) dance reels of 4 across. End with 4s+1s facing each other, NHJ with partner, (4s face down, 1s face up)
- 17-24 4s+1s Set+Link & dance circle 4H round to Left
- 25-32 2s+4s also 1s+3s dance Poussette 2 4 (1) (3)

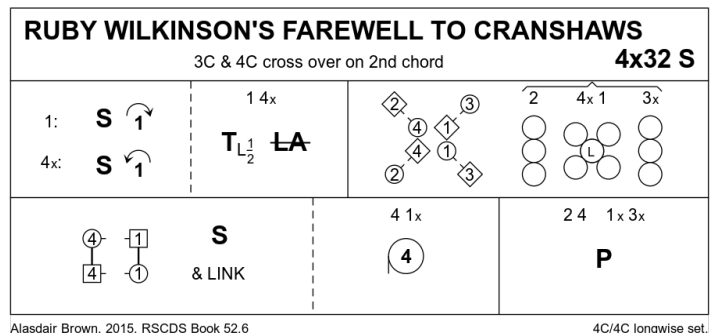

4 MISS HADDEN'S REEL J32 · 3/4L

RSCDS: RSCDS XXIII 5 · Crib: MiniCribs · Diagram: Keith Rose's Diagrams

- 1-8 1s+2s+3s circle 6H round & back
- 9-16 1s set & cast (2s step up); 2s+1s+3s all turn RH to end in Allemande hold ready for ...
- 17-24 2s+1s+3s dance Allemande
- 25-32 3s+1s+2s Adv+Ret for 2 steps; 3s cast to 3rd place **while** 1s+2s dance up, 1s casting to 2nd place. 2 1 3 2nd turn bars 29-32: 3s cast to bottom & dance up to 3rd place, original 1s cast to bottom, 2s dance up to place

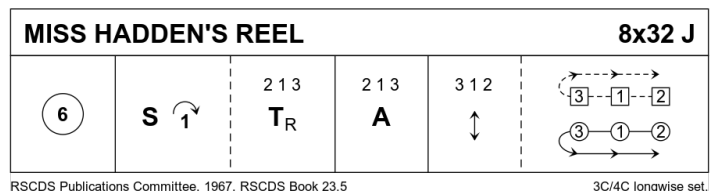

5 MRS STEWART OF FASNACLOICH R32 · 3/4L

RSCDS: *The Leaflet Dances with Music · Crib: MiniCrib*s · Diagram: Keith Rose's Diagrams

- 1-8 1s & 2s Petronella turn into centre & set, 3/4 turn partner RH & 1s+2s dance 1/2 RH across (1s end in 2nd place own sides)
- 9-16 1s cross down RH through 3rd place to dance reel of 3 with 2s+3s on opp sides (2s+3s start passing RSh on Ladies' side & LSh on Men's side). 1s end facing 2nd crnrs
- 17-24 1s dance 1/2 diag reel of 4 with 2nd corners, turn LH for 1/2 LSh reel with 1st crnrs passing LSh to end BtoB in centre (1M face up 1L down)
- 25-32 1s circle 3H round to left (Man with 3s & Lady with 2s), 1s drop LH & open up to circle 6H round to left 1/2 way & all set

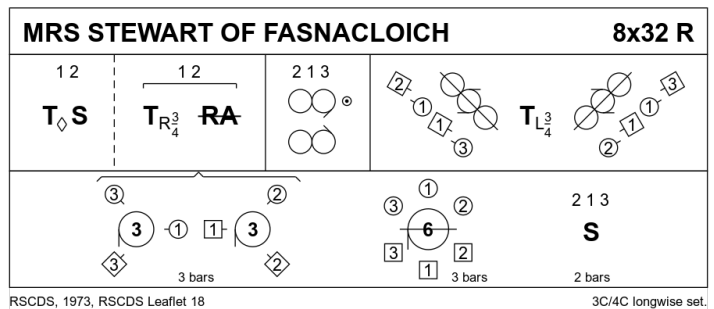

6 YSOBEL STEWART OF FISH HOEK S32 · 3/4L

Mervyn C Short: *RSCDS LII 8 · Crib: MiniCrib*s · Diagram: Keith Rose's Diagrams

- 1-8 1s+2s dance the Tourbillon
- 9-12 1s set advancing to 1st corners & turn corners 2H into lines of 3 across, 1L between 2s, 1M between 3s
- 13-16 1s set advancing to 2nd corners & turn corners 2H to end 1s in 2nd place opp sides
- 17-24 1s pass LSh to dance 1/2 diag reel of 4 with 3rd corners, pass LSh to dance 1/2 diag reel of 4 with 4th corners. 1s end in 2nd place own sides
- 25-30 1L+3s (at top) & 1M with 2s (at bottom) dance 3H round to Left (3 bars), 1s drop LH and 1L leads 3s down Ladies' side, 1M leads 2s up Men's side into circle 6H 1/2 round to Left. 2 (1) 3
- 31-32 1s cross RH to own sides. 2 1 3

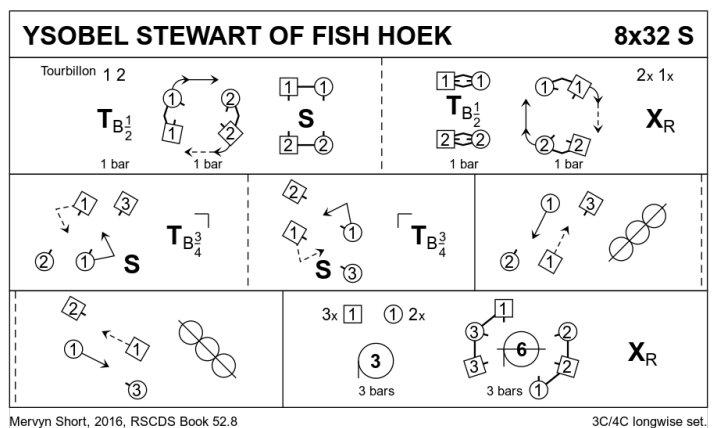

7 RAY MILBOURNE R32 · 4/4L

Derek Haynes: *Carnforth Collection of SC Dances 1 · Crib: MiniCrib*s · Diagram: Keith Rose's Diagrams

2s & 4s start on opp sides

- 1-8 1s & 4s cross RH, cast in 1 place & dance 1/2 Figs of 8 round end couples
- 9-16 1s+4s dance 1/2 R&L, all dance 1/2 reels of 4 on sides
- 17-24 3s+1s also 4s+2s dance Men's Chain
- 25-32 All circle 8H round & back

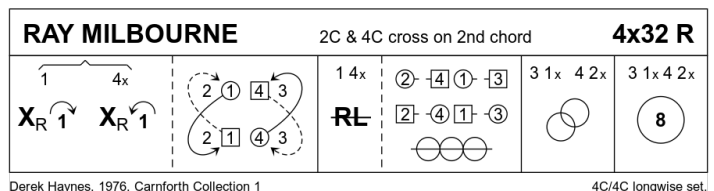

8 BILL CLEMENT MBE J32 · 3/4L

John Wilkinson: *RSCDS XLVII 1 · Crib: MiniCrib*s · Diagram: Keith Rose's Diagrams

- 1-8 1s set & dance down between 3s & cast up to end LH with partner facing 1st crnrs
- 9-16 1s set & turn inwards to face 3rd crnrs, 1s set to 3rd crnrs & turn crnrs LH to end RH with partner facing 2nd crnrs
- 17-24 1s set & turn inwards to face 4th crnrs, 1s set to 4th crnrs & turn crnrs RH to end 2nd place own side
- 25-32 2s+1s+3s circle 6H round & back

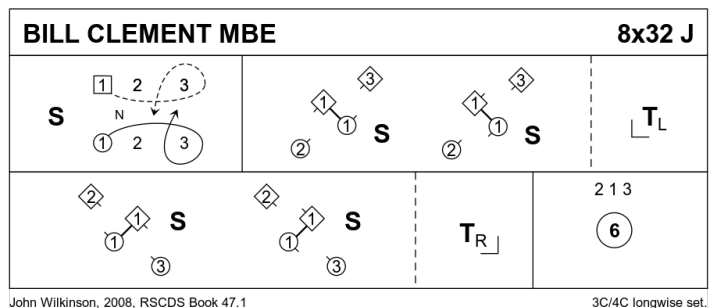

PROGRAMME ITEM – Interval

9 MRS STEWART'S JIG J32 · 3/4L

Frans Ligtmans: RSCDS XXXV 1 · Crib: MiniCribbs · Diagram: Keith Rose's Diagrams

- 1-8 1s set, 1L followed by partner casts 2 places, 1L crosses (below 3s) & casts up on Men's side to 2nd place facing down **while** 1M dances round 3L & up the middle to 2nd place Ladies' side facing down
- 9-16 2s+1s+3s dance Grand Chain, end with 2M & 1M facing out
- 17-24 2s+1s dance Ladies' Chain
- 25-32 2s+1s+3s Adv+Ret; 1s turn 1.1/2 RH to own sides. 213

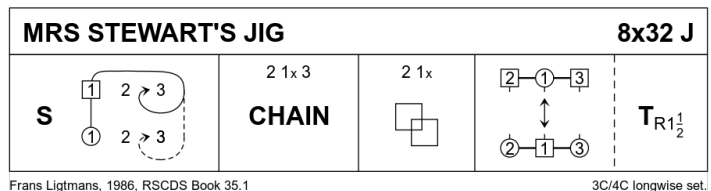

10 THE EARL OF MANSFIELD R48 · 4/4L

John Drewry: The Leaflet Dances with Music · Crib: MiniCribbs · Diagram: Keith Rose's Diagrams

- 1-8 1s+2s circle 4H round & back
- 9-16 1s+2s also 3s+4s face on sides, all set & change places RH, all set & change back RH
- 17-24 1M reel of 3 with 2s (LSh to 2L) picking up partner in prom hold to complete reel as 3M dances similarly with 4s, 1s+3s end on Men's side facing in/down (2s & 4s in original places)
- 25-32 3s followed by 1s dance down below 4s, 3s cast, in & lead up to top, cross & cast back to place **while** 1s cast up & turn LH to face 1st crnrs(2s step up 31-32)
- 33-40 1s turn 1st corners RH pass partner RSh, turn 2nd corner LH, pass LSh to end 2nd place in centre facing up
- 41-48 1L+2L+3L dance RH across (on side) as 1M+2M+3M LH across, 1s followed by 3s dance down to 4s & Ladies dance LH across as Men RH across to end 2 3 4 1

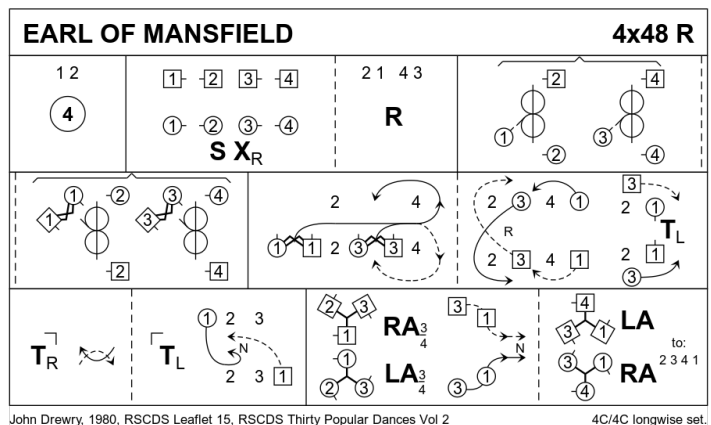

11 MISS GIBSON'S STRATHSPEY S32 · 3/4L

Derek Haynes: The Leaflet Dances with Music · Crib: MiniCribbs · Diagram: Keith Rose's Diagrams

- 1-8 1s+2s set, turn partners 2H opening out into 4H round
- 9-16 1s+2s dance the Knot, 1s turn LH to end facing 1st corners
- 17-24 1s turn 1st corners RH, partner LH, 2nd corners RH & partner 3/ 4 LH finishing in middle facing opp sides ready for ...
- 25-32 1s dance RH across, (1M with 3s & 1L with 2s), pass partner RSh & dance LH across with other couple, 1s end in 2nd place

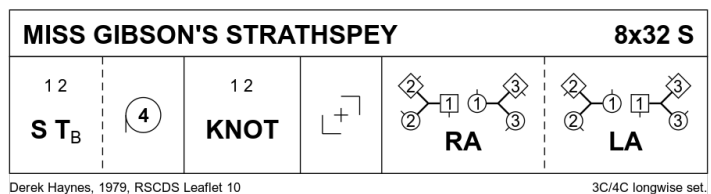

12 MAJOR IAN STEWART J32 · 3/4L

John Drewry: RSCDS XXXV 4 · Crib: MiniCribbs · Diagram: Keith Rose's Diagrams

- 1-8 1s+2s 1/2 turn partners RH & dance RH across 1/2 way, 2s+1s full turn partner RH ending with 2s at top & 1s in 2nd place
- 9-16 2s+1s+3s dance reels of 3 on own sides (1L dances in & up as 1M dances in & down to start) & 1s end facing 1st corners
- 17-24 1s dance 'Hello-Goodbye' setting ending with petronella turn to 2nd places
- 25-32 2s+1s+3s circle 6H round to the left for 6 steps, pivot & chase back to places

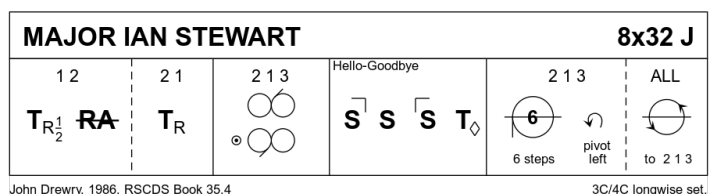

13 MISS JOHNSTONE OF ARDROSSAN R32 · 5/5L

Roy Goldring: *Thirty Popular Dances, Volume Two* · Crib: *MiniCribs* · Diagram: *Keith Rose's Diagrams*

- 1-8 1s set & cast 1 place, 1s followed by 3s dance up & cast - 1s to 3rd place & 3s to 2nd place
- 9-16 1s cross down & dance reflection reels of 3 with 4s+5s on opposite sides - 1s end in 3rd place opposite sides
- 17-24 1s cross up & dance reflection reels of 3 on own sides with 2s+3s - 1s ending in 3rd place own sides
- 25-32 1s set & cast down 1 place, 1s followed by 5s dance up between 4s & cast - 1s to 5th place & 5s to 4th place

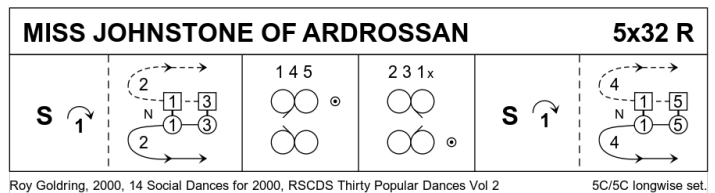

14 MISS MILLIGAN'S STRATHSPEY S32 · 3/4L

RSCDS: *The Leaflet Dances with Music* · Crib: *MiniCribs* · Diagram: *Keith Rose's Diagrams*

- 1-8 1s+2s circle 4H round to left, 1s face 2s NHJ with partners. 1s+2s set, 1s turning towards each other to face up, then 1s cast **while** 2s dance up & face out
- 9-16 2s+1s+3s dance reflection reels of 3 on own sides 1s dancing in between 3s to start. All take hands where possible
- 17-24 2s+1s+3s set, 2s+1s 1/2 turn LH, 1s followed by 2s lead down between 3s, cross & cast up on own sides
- 25-32 1s+2s dance the Knot

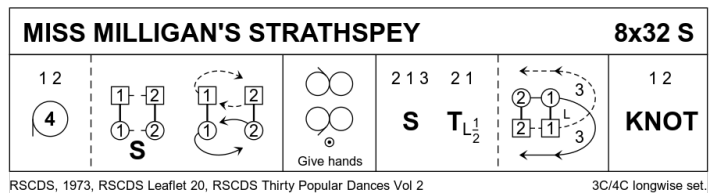

15 MISS ALLIE ANDERSON J32 · 3/4L

Mina Corson: *The Leaflet Dances with Music* · Crib: *MiniCribs* · Diagram: *Keith Rose's Diagrams*

- 1-8 All clap as 1L+2L+3L dance RSh round partners; 3s followed by 2s & 1s lead down
- 9-16 All 1/2 turn (Lady under Man's R arm) & 1s followed by 2s & 3s lead back to places on opposite sides; 1s+2s+3s set on sides, 1/2 turn partner RH ending in centre of dance facing up ready for ...
- 17-24 1s+2s+3s dance Promenade
- 25-32 1s+2L dance RH across, 1M ends in 2nd place (2M step up 27-28); 1s+2M dance LH across (2L step up 31-32), 1s end in 2nd place own side. 2 1 3

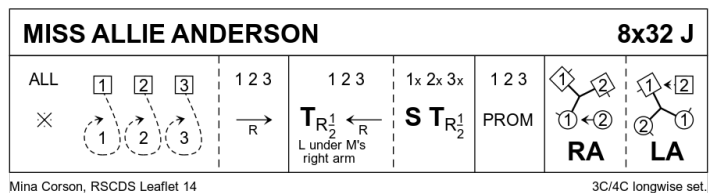

16 MISS FIDLER'S REEL R32 · 3/4L

Peter Cass: *Another Newcastle Collection* · Crib: *MiniCribs* · Diagram: *Keith Rose's Diagrams*

- 1-8 1s dance Inveran reels with 2s+3s
- 9-16 1s lead down to bottom & back to top
- 17-24 1s cross RH, cast 1 place & turn RH 1.1/2 times to 2nd places
- 25-32 2s+1s+3s circle 6H round & back

